

Vertical Sump Pumps, Type ET and Type ETT

- ✓ Close coupled design
- ✓ For normal or aggressive fluids
- ✓ Flow capacity up to 120 m³/hr
- ✓ Head up to 55m
- ✓ Immersion depths from 500mm to 2000mm
- ✓ Suction tube extension up to 1.5m
- ✓ Available in Polypropylene (PP), PVDF and UHMW-PE for abrasive duties
- ✓ Sizes from 15-80mm to 65-250mm
- ✓ Dry running safe (Type ETT)

Vertical sump pumps - depth from 500mm with steps of 250mm up to 2000mm. Pump casing and impeller corresponding to type NM.

- The SS-shaft is covered by a corrosion resistant and diffusion-tight thermoplastic sleeve and guided by slide bearings of PTFE or carbon/SiC and SiC/SiC, medium-lubricated.
- A special pressure drop device prevents flushing of solids into the slide bearings and extends their service life.
- The shaft seal with a liquid filled labyrinth operates against vapour only and is not flushed by the medium.

Type ETT uses the modular type ET design and provides dry running capabilities.

- The slide bearings of HD-carbon/SiC are normally lubricated and cooled by the liquid. With ETT-pumps and if liquid is not available - e.g. up to an empty tank - the bearings are cooled by an air-stream through especially designed bearings and support tube.

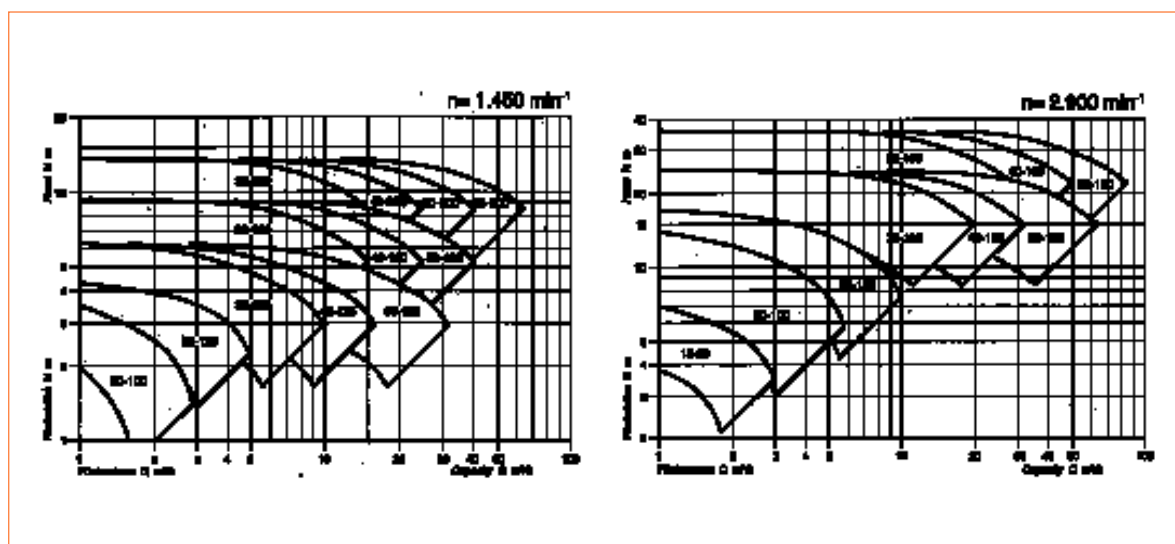
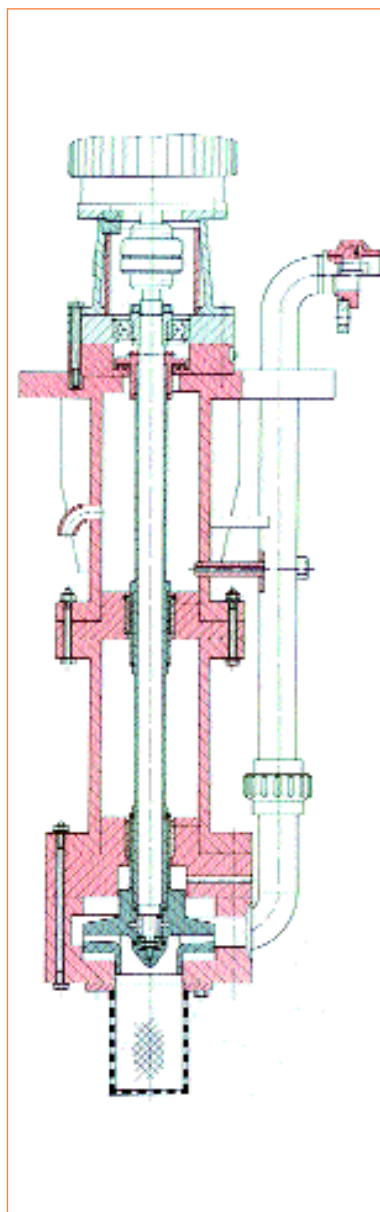

Dry Running Protected Vertical Sump Pumps, ETL and ETLB

- ✓ Dry running safe
- ✓ For clean, aggressive or abrasive fluids
- ✓ Flow capacity up to 104 m³/hr
- ✓ Head up to 36m
- ✓ Immersion depths from 300mm to 775mm
- ✓ Suction tube extension up to 1.5m
- ✓ Available in Polypropylene (PP), PVDF and UHMW-PE for abrasive duties
- ✓ Sizes from 15-60mm to 80-200mm

Sectional drawing of type range ETL with bearing housing outside of the tank.

Direct coupled sump pump, type ETLB, depth 300/500mm. ▼

Vertical sump pumps type ETL and ETLB run without medium-lubricated slide bearings.

Using the ASV modular system, they are designed from type ET.

Two types according to requirements:

ETL - Ball bearings located above the medium with large axial distance for smooth operation. Driver is a standard IEC electric motor.

Speed $n = 1.450$ and 2.900 min^{-1} . Standard depth 500 and 750mm, with extension pipe up to 2.000mm.

ETLB - Directly coupled design with special three-phase motor.

Standard depth 300 and 500mm; extension pipe up to 1.500mm.

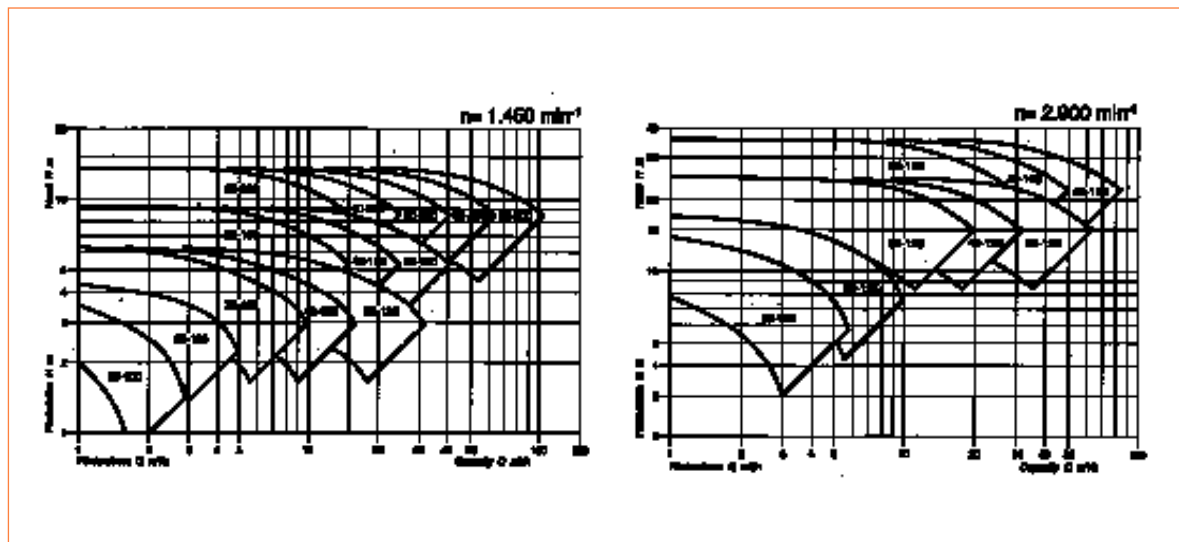
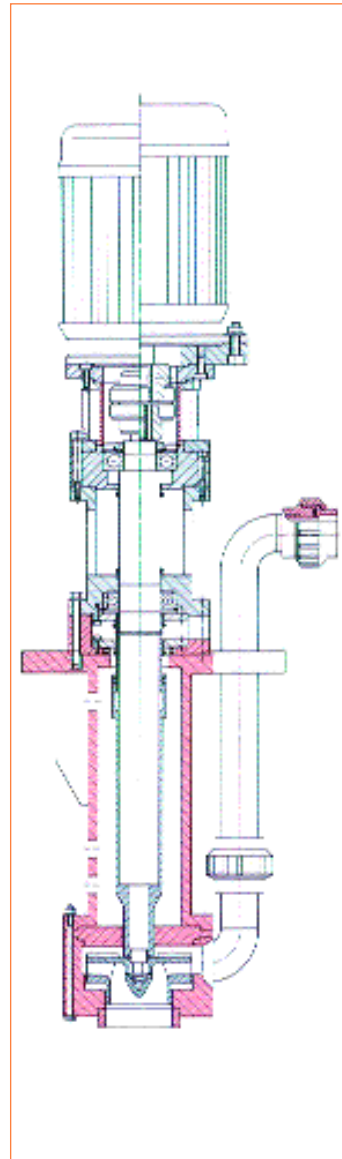

Vertical Sump Pump, Pull-Off Design, Type ETLB-G

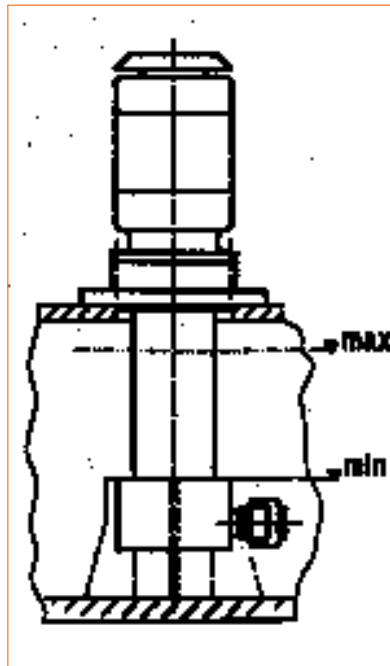

- ✓ Space-saving design
- ✓ Dry running safe
- ✓ No piping outside the module
- ✓ Flow capacity up to 30 m³/hr
- ✓ Head up to 25m
- ✓ Immersion depths from 275mm or 475mm
- ✓ Available in Polypropylene (PP) or PVDF
- ✓ Sizes from 20-100mm to 40-125mm

The ASV vertical sump pumps type ETLB-G are widely used in printed circuit board (PCB) manufacturing. They have the advantage of being able to use space saving pipeline installations inside the module container. By this any leaking to the environment and/or crystallisation is avoided.

The motor, suspension pipe and impeller can be easily removed without disconnecting from the piping, greatly simplifying maintenance. No screws or bolts are required during this process.

Vertical Sump Pump Type ETLB-T

Dry-well Design

- ✓ For external installation
- ✓ No leaking - controlling level of fluid and returning it into a reservoir tank
- ✓ Dry running safe
- ✓ Flow capacity up to 30 m³/hr
- ✓ Head up to 25m
- ✓ Available in Polypropylene (PP) or PVDF
- ✓ Sizes from 15-60mm up to 40-125mm



Dry-well design sump pumps are used for such applications where due to space, process technology or media, sump pumps have to be installed outside of the tank.

Applications include the pumping of fluids used in environmental technology, sewage treatment, laquering plants and in the recycling industry.

Vertical Sump Pump Type ETLB-X

Multi Stage

- ✓ 2 or 3 stage design
- ✓ Sizes: 2-stage 32 - 125 - 2
3-stage 25 - 100 - 3
- ✓ Dry running safe
- ✓ Flow capacity up to 28 m³/hr
- ✓ Head up to 42m
- ✓ Available in Polypropylene (PP) or PVDF
- ✓ Immersion depth 275mm or 475mm



Standard Version



Dry-well Version

ASV close coupled sump pumps are designed for vertical installation in non-pressure containers, open tanks or pits.

Applications include the pumping of fluids used in chemical or pharmaceutical manufacturing, metal finishing, or water and waste treatment.