

Self-Priming Centrifugal Pump, Type SAP

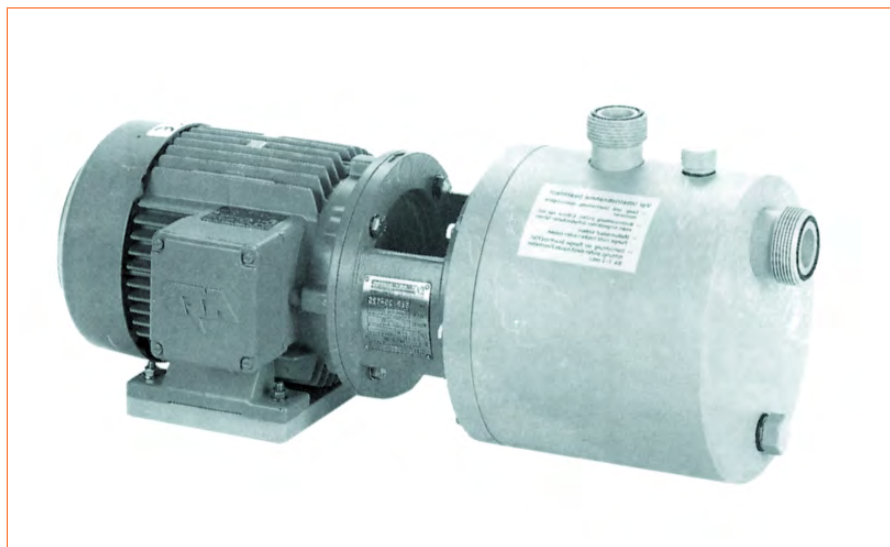

- ✓ Self-priming
- ✓ Available in Polypropylene (PP), Polyethylene (HDPE) and PVDF
- ✓ Flow capacity up to 29 m³/hr
- ✓ Head up to 33m
- ✓ Sizes from 20-125mm to 40-125mm

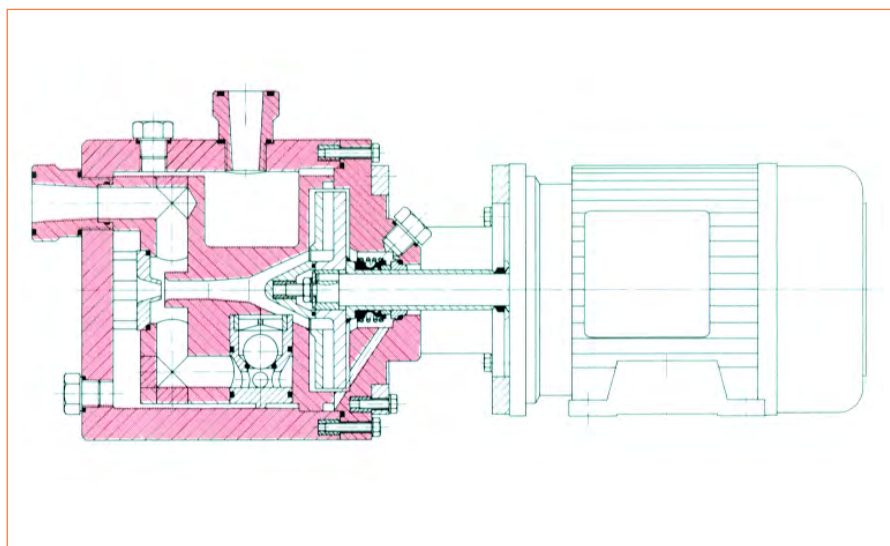

Self-priming centrifugal pumps, type SAP offer a novel combination of direct coupled pumps.

This combination of pumps has the possibility to double the capacity by means of integrated valve-technology and to reach a suction head up to approx. 7.0m.

- All parts that are in contact with the liquid are made of high quality thermoplastic materials such as PP, HD-PE and PVDF.
- Shaft sealing by single or double acting mechanical seal on corrosion resistant shaft sleeve.
- The pumps are directly coupled with an IEC standard electric motor with $n=2.900 \text{ min}^{-1}$.
- Self-priming pumps type SAP are in use for handling low viscous, neutral or aggressive liquids or mixed fluids.

